

TS34 tool setting probe

www.renishaw.com/ts34

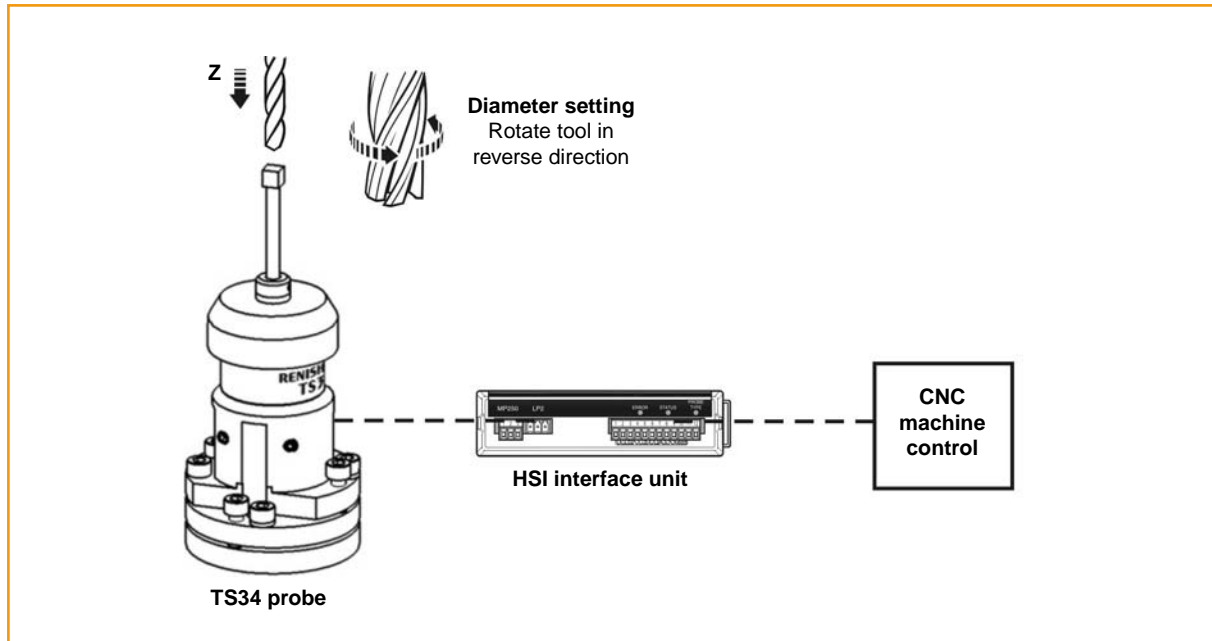

Rapid tool setting and tool wear monitoring for CNC machining centres

The TS34 probe is used for tool setting on CNC machining centres and is available with rear or side exit cable.

The achievable tolerance setting of tools depends upon the flatness and parallelism of the stylus tip setting. A value of 5 µm (0.0002 µin) front-to-back and side-to-side is easily achievable over the flat portion of the stylus tip (parallelism of 5 µm [0.0002 µin] across the axes of square tip styli is sufficient for the majority of tool setting applications).

System components

TS34

The TS34 probe is mounted on the machine table. Tool tips are presented against the stylus cube to check tool length and diameter. This data enables tool offsets to be quickly and accurately established. Probing routines are also used to update tool offsets for wear and thermal growth. Proven software is available from Renishaw.

HSI

The HSI is a hard-wired transmission interface, which conveys and processes signals between the TS34 and the CNC machine control, where the signal is further processed and used to set tool data registers.

Benefits

- One of the standard tool setting probes for machining centres.
- Compact table mounting.
- Precise tool length and diameter measurement.
- Suitable for high speed broken tool detection.
- Rotating tools can be checked without wear to the tool or stylus.
- The probe is protected by a swarf deflector, preventing dirt and chips from entering the system.

Data sheet
TS34 tool setting probe

TS34 dimensions

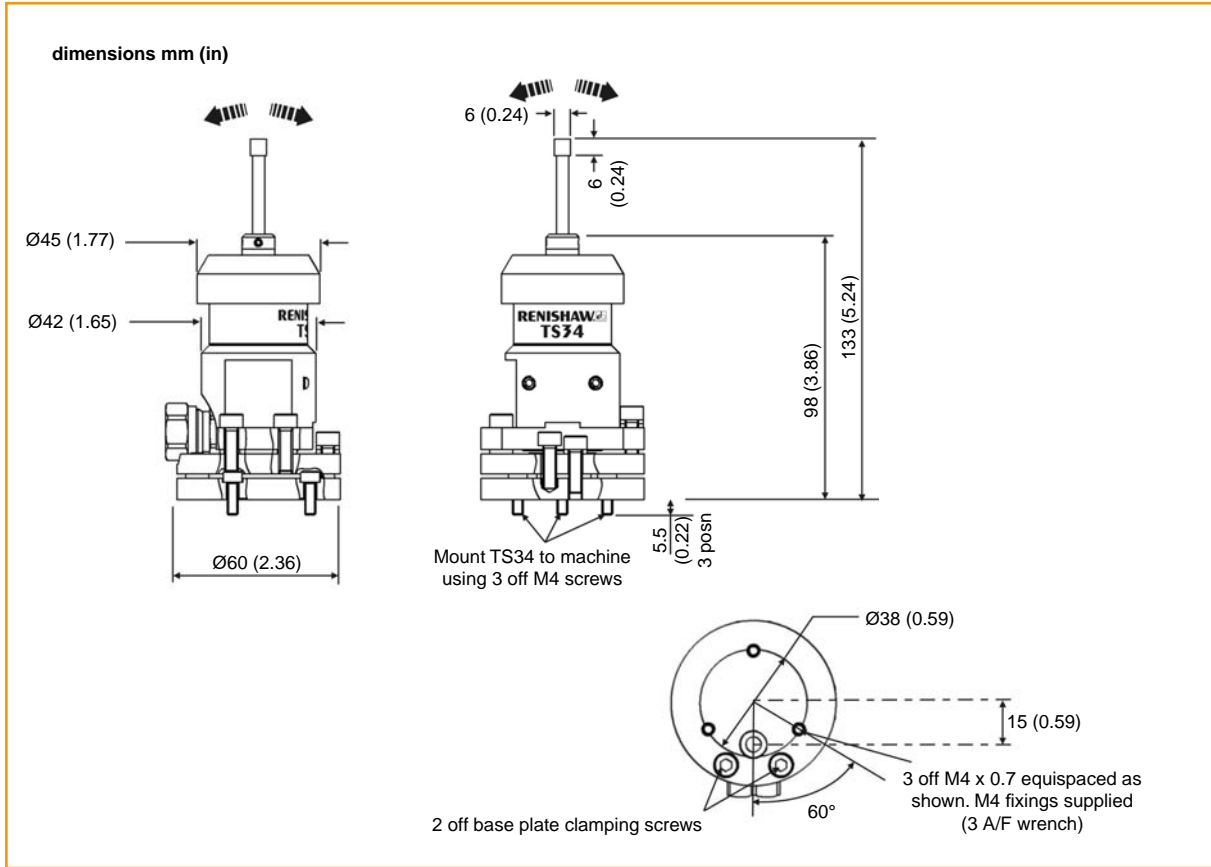

Specification

Principal application	Tool setting probe for machining centres
Dimensions	Length 133 mm (5.24 in) Diameter Ø60 mm (2.36 in)
Receiver/interface	HSI
Sense directions	Omni-directional ±X, ±Y, +Z
Uni-directional repeatability (maximum 2s at stylus tip)	1 µm (0.00004 µin) is certified with a 50 mm (1.97 in) stylus at a velocity of 480 mm/min (1.57 ft/min) in the centre of the stylus tip
Stylus trigger force	XY low force 0.65 N, 65.0 gf (2.29 ozf) XY high force 1.42 N, 142 gf (5.0 ozf) Z 5.5 N, 550 gf (19.4 ozf)
Stylus overtrave	XY max force 2.45 N, 245 gf (8.64 ozf) at ±9° +Z 25 N, 2500 gf (88.18 ozf) at 4 mm
Environment	IP rating IPX8 Storage temperature -10 °C to 70 °C (14 °F to 158 °F) Operating temperature +5 °C to 60 °C (41 °F to 140° F)

NOTE: For stylus recommendations, please refer to the Styli and accessories technical specification, H-1000-3200.

Recommended connection diagram for TS34 with HSI interface

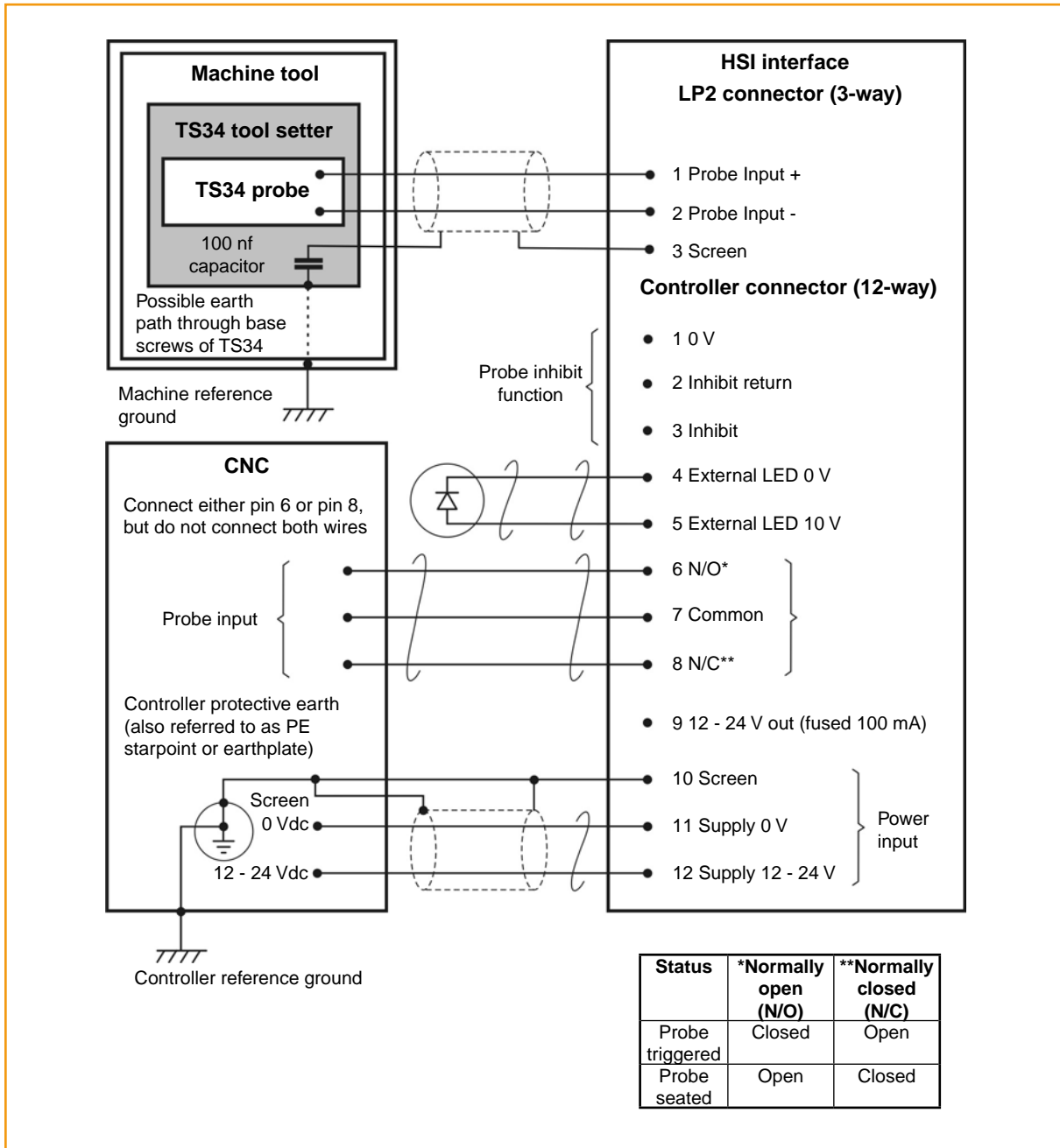

NOTE: When connecting the TS34 probe to the HSI interface, please use the connection labelled LP2.

Parts list – please quote the part number when ordering equipment

Type	Part no.	Description
TS34 rear exit kit	A-2197-2100	TS34 R/E assembly, PS1-14 square tip stylus, spanner assembly and tool kit.
TS34 side exit kit	A-2197-3000	TS34 S/E assembly, PS1-14 square tip stylus, spanner assembly and tool kit.
PS1-13 stylus	A-5000-3212	6x6x6 tungsten carbide tip stylus 53 mm long.
PS1-14 stylus	A-5000-6701	6x6x6 tungsten carbide tip stylus 43 mm long.
Grubscrew	P-SC03-0303	M3 x 3 hexagonal screw socket for securing stylus.
Plinth spacer	M-5401-0122	TS34 plinth spacer.
HSI interface	A-5500-1000	HSI probe system interface with DIN rail mounting and three terminal blocks, quick-start guide and packaging.
C spanner	A-2008-0332	C spanner for removing the probes front cover
Publications. These can be downloaded from our web site at www.renishaw.com		
TS34	H-2197-8500	Installation and user's guide: TS34 tool setting probe.
HSI	H-5500-8554	Installation guide: HSI Hardwired system interface.
Styli	H-1000-3200	Technical specification: Styli and accessories.
Software features	H-2000-2289	Data sheet: Probe software for machine tools - illustrated features.
Software list	H-2000-2298	Data sheet: Probe software for machine tools - list of programs.

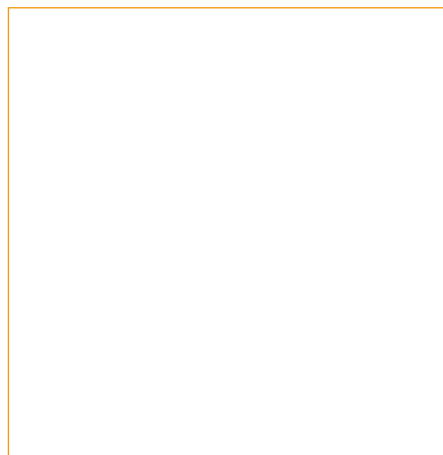

**For worldwide contact details, please visit our
 main web site at www.renishaw.com/contact**

